

PLANTA COBERTURA/ÁTICO

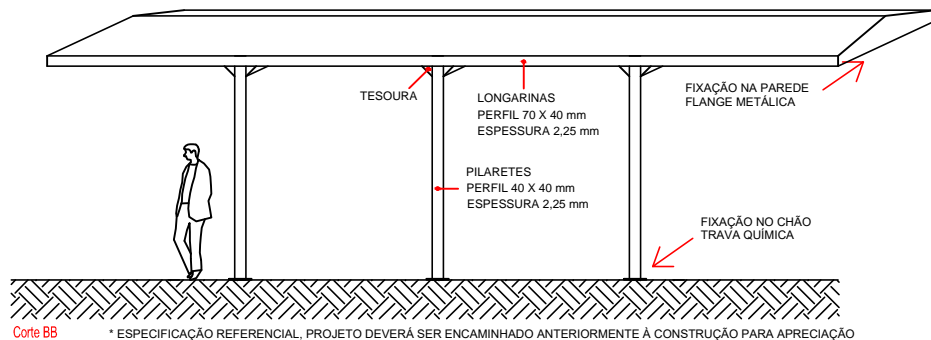
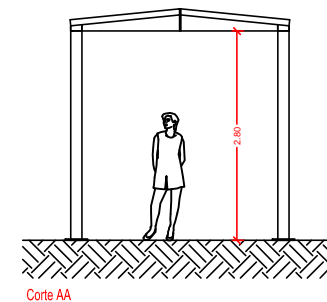
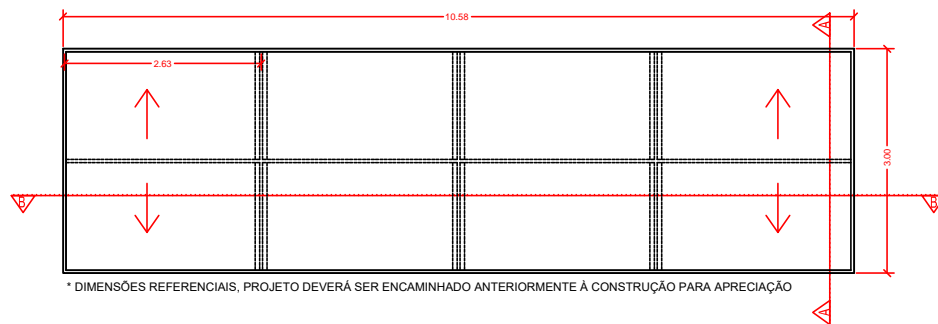

**MATERIAL
POLICARBONATO ALVEOLAR**

TRIBUNAL DE CONTAS DO ESTADO DE SÃO PAULO		
TÍTULO	PRÉDIO UR-20 SANTOS - AV. WASHINGTON LUIS, 299 - BOQUEIRÃO - CEP 11.055/001 - SANTOS/SP	FOLHA
ASSUNTO	DESENHO 9 - PROPOSTA DE DISPOSIÇÃO DA COBERTURA	ESCALA
		DATA
		S/E
		Rev. 12
		01/02